

CIRCUIT DIAGRAM

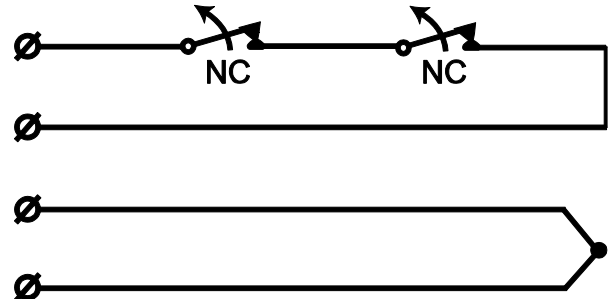

DISTANCE DIAGRAM – WOOD

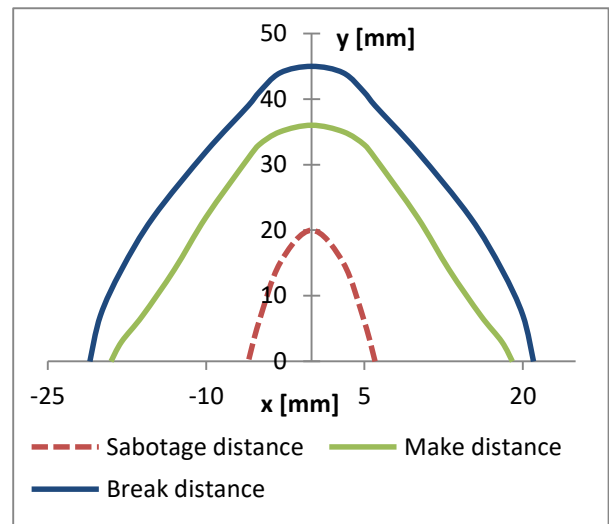

DESCRIPTION

MC 270-S56 is a heavy duty high security magnetic contact used in both alarm and security access control systems for protection of garage doors, industrial gates etc. against unauthorized opening and external magnetic field.

MOUNTING INSTRUCTIONS

- Contact and magnet should be installed in parallel, corresponding to each other. Offset will reduce the working distances and may result in faulty operation or lower security.
- Magnetic contact should be installed in accordance with the installation drawing.

TECHNICAL DATA

Working environment	wood	steel
Sabotage distance	max. 20 mm	max. 17 mm
Make distance	typ. 36mm	typ. 30mm
Break distance	typ. 45mm	typ. 37mm
Contact type	form A, SPST	
Switching voltage max.	48 V DC/AC	
Switching current max.	500 mA DC/peak AC	
Contact rating max.	10 W	
Cable	φ 3,4 mm, 4x0,182 mm ²	
Sleeving	1 m, φ 8,2 mm, stainless steel	
Operating temperature range	-40°C to +70°C	
Operating humidity	max. 95% RH	
Housing material	Aluminum	
Dimensions:		
Contact part	103 x 15 x 40 mm	
Magnet part	73,5 x 25 x 15 mm	

OPERATING PRINCIPLE

MC 270-S56 magnetic contact has two parts: the contact part with alarm and sabotage reed switches and the magnet part. In its neutral position the alarm reed switch remains closed under the force of the magnetic field. Opening the monitored object increases the distance between the reed switch and the magnet. This reduces the influence of the magnetic field on the reed switch until it opens and activates an alarm.

MC 270-S56 has an extra sabotage reed switch to protect the contact from sabotage with an external magnet. When an external magnet is applied to the contact, the sabotage reed switch opens and activates an alarm. The sabotage switch can be also opened by the corresponding (friendly) magnet. The distance between the contact and the corresponding magnet, at which the sabotage reed switch opens is called sabotage distance.

Magnetic contacts should not be installed in the vicinity of strong magnetic fields.

INSTALLATION

Depending on the application, contact and magnet should be installed in one of the possible configurations. Installation drawings show the correct positioning of the contact parts. Contact and magnet should be installed in parallel, with plastic plugs corresponding to each other. Offset will reduce the working distances and may result in faulty operation or lower security. The contact should be mounted on the stationary part of the monitored object (ex. door frame) and the magnet on the movable part (ex. door leaf).

For sites where it is impossible to mount the contact directly, aluminum brackets and additional magnet parts are available. Brackets can be used to solve problems with aligning the contact with the magnet. Contact and/or magnet should be screwed to the oval slots in the brackets and adjusted to a suitable position.

Only non-ferromagnetic screws may be used for mounting the contact.

For the most adequate distance for mounting, magnetic part should be placed close to the contact part to get Sabotage distance, then move away magnetic part to get minimum Make distance.

After the installation, use an ohmmeter to check the electrical connections and test the operation of the magnetic contact.

RESISTORS (OPTIONAL)

MC 270-S56 is available in two additional options with resistors of the chosen value: MC 270-S56-R with one resistor parallel to the alarm switch and MC 270-S56-2R with two resistors in 2EOL configuration.

MC 270-S56-R:

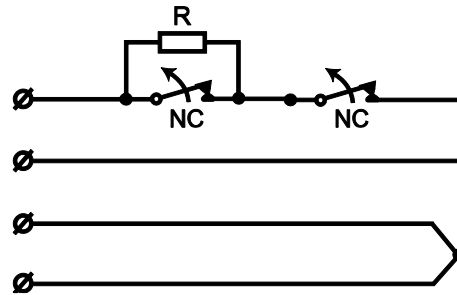

MC 270-S56-2R:

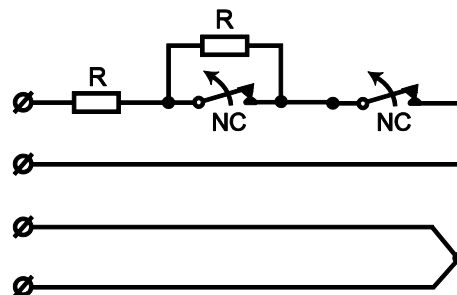

INSTALLATION DRAWING

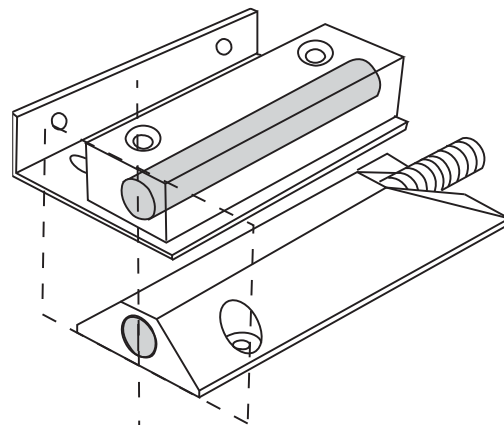

We reserve the right to changes without notice.