

Instruction Manual **MC 240-S45**



DESCRIPTION

MC 240-S45 is a heavy duty magnetic contact used in both alarm and security access control systems for protection of garage doors, industrial gates etc. against unauthorised opening.

MOUNTING INSTRUCTIONS

- Contact and magnet should be installed in parallel, corresponding to each other. Offset will reduce the working distances.
- The closer the contact/magnet is installed to the ferromagnetic surface, the lower the working distances. Use proper spacers/brackets.
- Magnetic contact should be installed in accordance with the installation drawings.

CIRCUIT DIAGRAM (MAGNET CLOSE BY)

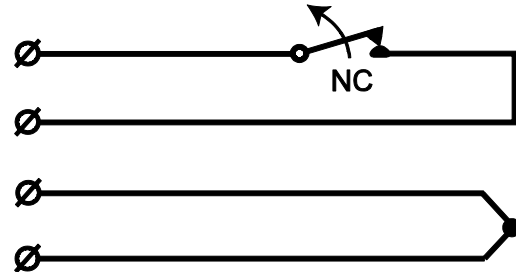

DISTANCE DIAGRAM - WOOD

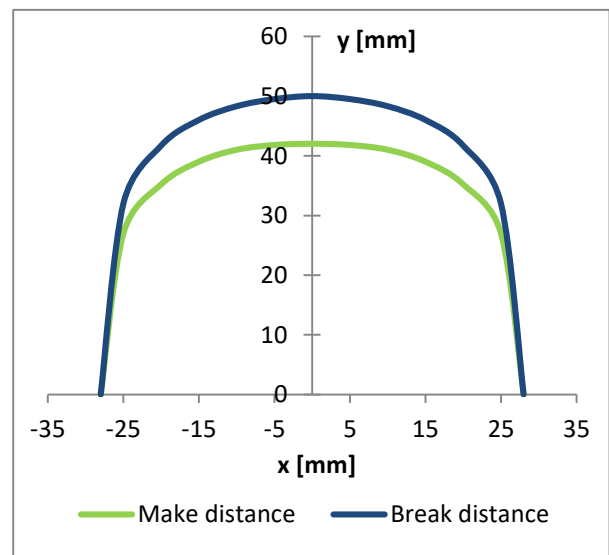

TECHNICAL DATA

Working environment	Wood	Steel
Make distance	typ. 42 mm	not recommended
Break distance	typ. 50 mm	not recommended
Contact type	form A, SPST	
Switching voltage max.	48 V DC/AC	
Switching current max.	500 mA DC/peak AC	
Contact rating max.	10 W	
Cable	φ 3,4 mm, 4x0,182 mm ²	
Sleeving	1 m, φ 8,2 mm, stainless steel	
Environmental class (EN50130-5:2011)	IIIA	
Operating temperature range	-40°C to +70°C	
Operating humidity	max. 95% RH	
Housing material	Aluminium	
Dimensions:		
Contact part	73,5 x 15 x 25 mm	
Magnet part	73,5 x 15 x 25 mm	
Approvals	VdS, class B - G 193513 , EN 50131-2-6 Grade 2 - EN-ST-000087	

OPERATING PRINCIPLE

MC 240-S45 magnetic contact has two parts: the contact part with a reed switch and the magnet part. In its neutral position the reed switch remains closed under the force of the magnetic field. Opening the monitored object increases the distance between the reed switch and the magnet. This reduces the influence of the magnetic field on the reed switch until it opens and activates an alarm.

Magnetic contacts should not be installed in the vicinity of strong magnetic fields.

INSTALLATION

Depending on the application, contact and magnet should be installed in one of the possible configurations. Installation drawings show the correct positioning of the contact parts. Contact and magnet should be installed in parallel, with plastic plugs corresponding to each other. Offset will reduce the working distances. The contact should be mounted on the stationary part of the monitored object (ex. door frame) and the magnet on the movable part (ex. door leaf).

For sites where it is impossible to mount the contact directly, aluminium brackets are available. Brackets can be used to mount the contact parts away from a ferromagnetic surface or to solve problems with aligning the contact with the magnet. Contact and/or magnet should be screwed to the oval slots in the brackets and adjusted to a suitable position.

Only non-ferromagnetic screws may be used for mounting the contact.

After the installation, use an ohmmeter to check the electrical connections and test the operation of the magnetic contact.

Warning: installation in ferromagnetic environment is not recommended.

INSTALLATION DRAWINGS

MC 240-S45 configurations:

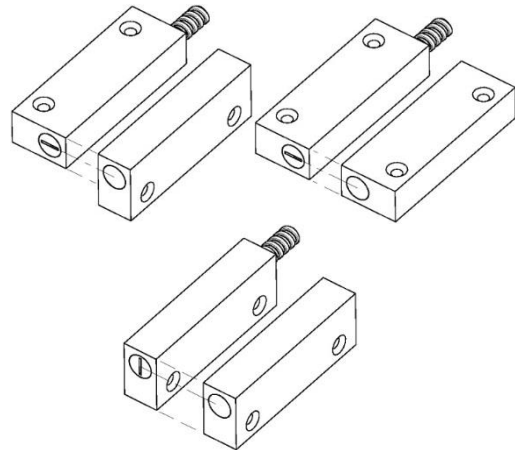

RESISTORS (OPTIONAL)

MC 240-S45 is available in two additional options with resistors of the chosen value: MC 240-S45-R with one resistor parallel to the alarm switch and MC 240-S45-2R with two resistors in 2 EOL configuration (see schematics below).

MC 240-S45-R:

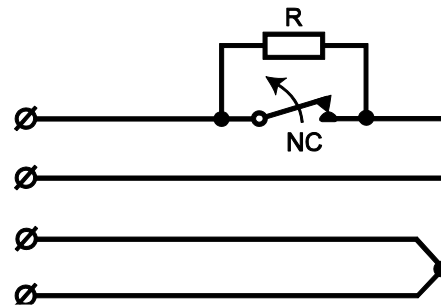

MC 240-S45-2R:

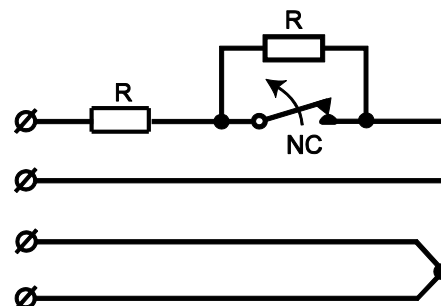

We reserve the right to changes without notice.