



GENERAL

IU 300 is a relay and analyzer unit to be used with glass break detectors in the GD 335 series of intruder alarm systems and up to 20 detectors can be connected to one IU 300 unit. When an alarm occurs the IU 300 relay and analyzer unit will activate a free relay opening which should be connected to the control panel input chosen at installation

FUNCTION

IU 300 measures resistance changes in a balanced alarm loop with the end of line resistance of 2,2K ohms. At a change of +/- 40% and a duration of at least 200ms an alarm will be raised on the normally closed alarm relay which will open for approximately 2-3 seconds or will remain open until a manual reset is completed. This depends upon the programming of the unit. Reset is completed either locally on the reset button or from a control panel by switching off the supply to the unit. IU 300 has a tamper switch protection should an attempt be made to open the lid.

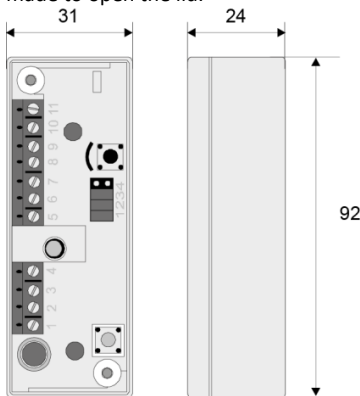

PROGRAMMING

The IU 300 has 4 programming jumpers, (see fig), with which the unit's basic settings are programmed

- S1 Closed The alarm relay stays open until manual reset is completed.
Open The alarm relay opens for 2-3 seconds and is automatically reset. The LED shows that it has been an alarm and the LED is manually reset.
- S2 Closed Power supply is 9 - 15V DC.
Open Power supply is 18 - 30V DC.
- S3 Closed Reset with negative trigger.
Open Must be open if S4 is closed.
- S4 Closed Reset with positive trigger.
Open Must be open if S3 is closed.

IMPORTANT!

Never mount the programming jumpers S3 and S4 at the same time. The IU 300 is supplied with jumper S1-S3 inserted.

MOUNTING

1. Select a suitable mounting point on an even surface. Mount the unit with the screws provided.
2. Connect the glass break detectors to the terminals 3 and 4. Connect the end of line resistor of 2.2K Ω , 1 %.
3. Connect as shown in the figure below.
4. Program the unit with jumper S1-S4.
5. Connect the power supply.
6. Test alarm in each detector individually to ensure that they all work correctly.

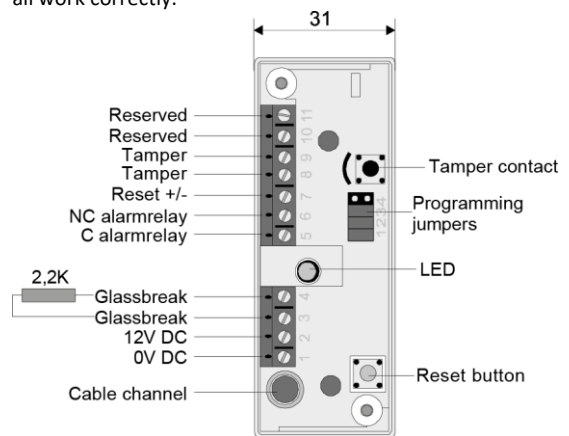

CONNECTING THE DETECTORS

The detectors in the GD 335-series are not polarity dependent. All conductors in the cable are tinned. One of the two pairs is taped together. If the tape is missing or the cable has been cut there will be no contact within the pairs and no connection between them. Connect the detectors as shown below.

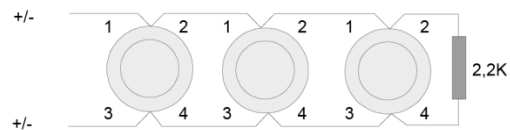

TECHNICAL DATA

Power supply:	9-15V DC 18-30V DC
Max ripple:	+/- 1Vpp
Current consumption:	10mA (@12V), 18mA (@30V)
Current consumption alarm:	16-28mA(@12V), 26-40mA(@30V)
Alarm output:	Relay contact, 33 ohm in series. 100mA / 35V
Alarm loop:	2,2k ohm, 1% EOL-resistance
- Threshold:	+/- 40%
- Response time:	200ms
- Reset time:	100ms
Temperature range:	-10 to +50° C
Humidity:	Max 93% R.H.
HF- immunity:	>10V/m, 80 -2700MHz
Dimensions:	92 x 31 x24 mm
Weight:	0,04 kg
Colour:	White or brown plastic housing or grey metallic housing
Approvals:	VdS Klasse B, G124501