



DESCRIPTION

The passive glass break detector, GD475-SJ, is EN Grade 3 certified and is suitable for float-, hardened- and laminated glass. The GD475-SJ is glued to the glass surface and will detect various attacks (including cutting tools) on the glass surface.

The detector requires an interface unit IU 400, which senses the changes in the state of the detectors and provides alarm and fault outputs. The difference from standard GD 475 is that GD 475-SJ has a spiral cord cable in PUR material and RJ10 (4/4) connector that easily connects to junction box JB 103-4.

The cable in PUR material (polyurethane), is more flexible in continuous use and can handle high mechanical stress. This makes the cable more elastic and resistant against sunlight, chemicals, etc.

GD 475-SJ approvals:

- EN 50131-2-7-2:2012+A1:2013 Grade 3
- EN 50130-5:2011 environmental class IIIA
- SSF1014:5 2016-03, SBSC Class 3

FEATURES

- Two wire, polarity independent, allows easy connection
- Spiral cable in quality PUR material for safe operations
- Detects attacks on many types of glass
- Detects crushing of glass
- Detects cutting through glass with tools
- Detection radius up to 2m
- High resistance to interference – rain, hail, foliage, doors shutting, etc
- No sensitivity adjustment required
- Suitable for 24-hour surveillance
- Low power consumption
- DAY/NIGHT LED control
- Potted electronics with IP 67 rating
- Easy connection using junction box JB 103-4

The detector GD 475-SJ is connected with RJ10 to JB 103-4. PINS 5&6 in JB 103-4 are then connected polarity independent to IU 400 PINS 3&4.

OPERATING PRINCIPLE

The GD 475-SJ uses a piezoelectric sensor to monitor the vibration signature of the glass pane that occurs when it is crushed or cut with tools. The signal has a special signature with a broad spectrum and high amplitude that the electronics detects, then generates a current increase and illuminates the LED. The GD 475-SJ has a built-in self-control and voltage monitoring. Fault is indicated by a flashing LED and a pulsating current increase. The indication is controlled by a DAY and NIGHT function. With 8Vdc on the power input, DAY mode is active and LED lights up at alarm and with pulsating shine in case of failure. At 6Vdc, NIGHT mode is active and LED is switched off in case of alarm or error.

Resetting the detector after alarm can be done in two different ways:

- Disconnect power to the detector
- Switch from DAY to NIGHT mode

WIRING

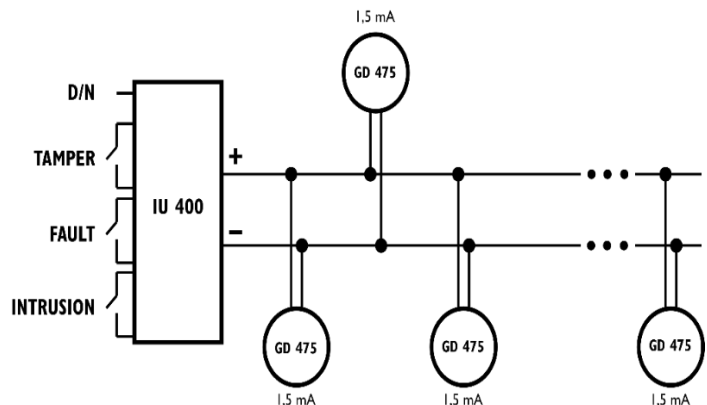
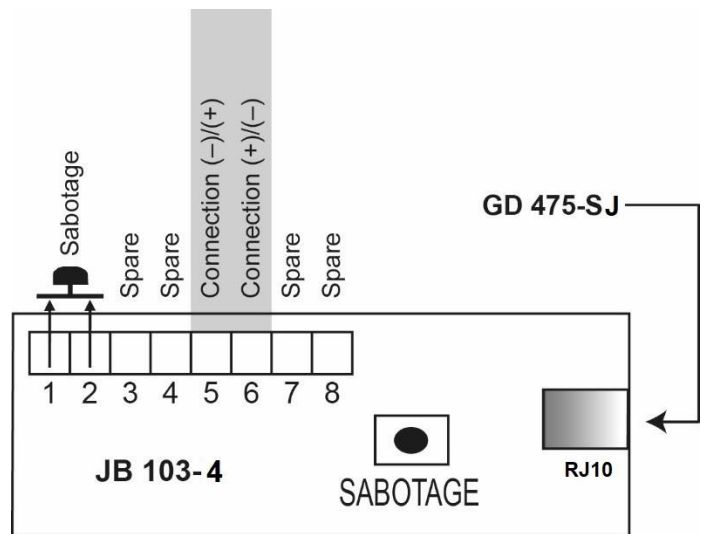

Installation

Notice #1: Correct gluing of the detector is essential for its function. Follow the installation instructions carefully.

Notice #2: GDK 100 adhesive kit must be used to ensure that the detector remains in place over time.

Procedure:

1. Before installation, test the detector using 5000 tester. Use the 12 V output of the GVT-5000 tester to test the detector.
2. Select the spot on the window pane if possible at about 5 cm distances from the frame. Distance between the detector and the frame must not be lower than 2 cm.

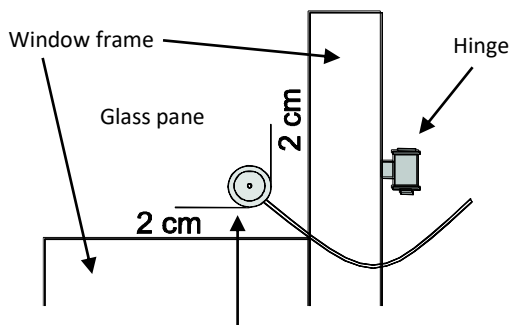

Minimum distances between detector and window

3. Clean the glass surface with the cleaning solvent (bottle no. 1). Let the surface dry.
4. Apply the enclosed sticker template for precise installation.
5. Clean the detector's bottom surface with the brown graining pad to remove any grease.
6. Apply activator (bottle no. 2) on the bottom surface of

the detector and on the installation spot. The sticker template (if used) will prevent staining the glass outside the installation area. Let the surfaces dry for 1-2 minutes.

7. Place a small drop of glue (bottle no. 3) in the centre of the detector's bottom surface and spread it evenly in a thin layer with enclosed triangular spatula. A thin layer is very important for a good and fast bond.
8. Press and hold the detector against the glass surface on the selected spot until you feel it adheres. (10 sec).
9. Let the glue harden for another 5 minutes before you start working with the cables.
10. Remove the surplus glue from the side of the detector using the triangular spatula. Remove the sticker template (if used).

See also <https://www.youtube.com/watch?v=fZd4SIEXbHI&t=13s>



TECHNICAL DATA

Type of protected glass	Float and laminated glass (For other glass types and thicknesses, pls. contact Alarmtech)
Glass thickness	Float 4 mm to 6 mm, laminated P1A-P8B
Detection radius	2 m (P8B 1 m)
Voltage range across detector in EOL loop	5– 15 VDC
Current consumption quiescent	1.7 mA
Current consumption alarm	5 mA
Alarm output	Transistor
Alarm indication	LED, DAY/NIGHT controlled
Day and Night levels on alarm loop	DAY=8 V, NIGHT=6 V on the loop
Alarm time	Latches in case of alarm
Alarm reset	EOL loop voltage across detector below 1 V
Low voltage alarm or fault in electronics	<5V indicated by flashing LED
Cable in Quality PUR	Spiral cable in PUR, 4 core (2 connected), length 35 cm – 70 cm (approx.)
Environmental class EN50130-5:2011, VdS 2110	IIIA
Operating temperature range	-40°C till +55°C
Operating humidity	max. 95% RH
Housing material	ABS Plastic in white or black colour
Dimensions	Φ 27 mm, H 11 mm
Approvals (together with analyser unit IU 400)	EN 50131-2-7-2 Grade 3 (EN-ST-000243), SSF 1014-5 Klasse 3 (17-132), VdS 2332 Klasse B (G121503), F&P (10.212-13139), FG (GD-1011/18)