



**DESCRIPTION**

The passive glass break detector GD 470-SJ is suitable for float and laminated glass. The GD 470-SJ is glued to the glass surface and will detect various attacks (including cutting tools) on the glass surface. Difference from standard GD 470 is that GD 470-SJ comes with a spiral cord and RJ12 6/6 connector that easily connects to junction box JB 103-6.

The GD 470-SJ shares the design with GD 475-SJ but has a relay built in for the alarm output. This enables the GD 470-SJ to be connected directly to the central alarm unit, no intermediate interface unit is necessary. The GD 470-SJ is independent of the polarity, just as GD 475-SJ.

**FEATURES**

- Relay alarm output
- Polarity independent
- Detects attacks on many types of glass
- Detects crushing of glass
- Detects cutting through glass with tools
- Detection radius up to 2m

- High resistance to interference – rain, hail, foliage, doors shutting, etc
- No sensitivity adjustment required
- Suitable for 24 hour surveillance
- Low power consumption
- DAY/NIGHT LED control
- Potted electronics with IP 67 rating
- Easy connection using junction box JB 103-6

**OPERATING PRINCIPLE**

The GD 470-SJ uses a piezoelectric sensor to monitor the vibration signature of the glass pane that occurs when it is crushed or cut with tools. The signal has a special signature with a broad spectrum and high amplitude that the electronics detects, then opens the alarm relay and illuminates the LED. The GD 470-SJ has a built-in self-control and voltage monitoring. Fault is indicated by a flashing LED and a pulsating current increase (alarm relay is closed). The indication is controlled by a DAY and NIGHT function. With 8Vdc on the power input, DAY mode is active and LED lights up at alarm and with pulsating shine in case of failure. At 6Vdc, NIGHT mode is active and LED is switched off in case of alarm or failure.

Resetting the detector after alarm can be done in two different ways:

- Disconnect power to the detector
- Switch from DAY to NIGHT mode

**WIRING**

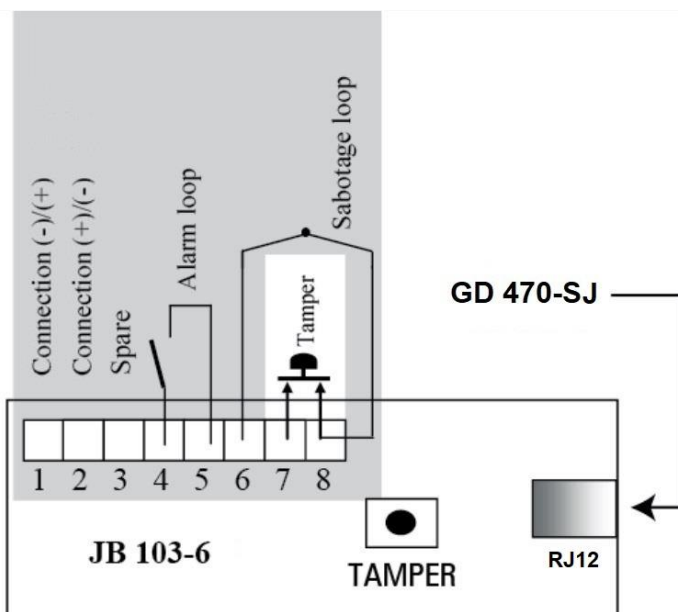

## INSTALLATION

**Notice #1: Correct gluing of the detector is essential for its function. Follow the installation instructions carefully.**

**Notice #2: GDK 100 adhesive kit must be used to ensure that the detector remains in place over time.**

### Procedure:

1. Before installation, test the detector using GVT-500 or GVT-5000 tester. Use the 12 V output of the GVT-5000 tester to test the detector.
2. Select the spot on the window pane if possible at about 5 cm distances from the frame. Distance between the detector and the frame must not be lower than 2 cm.

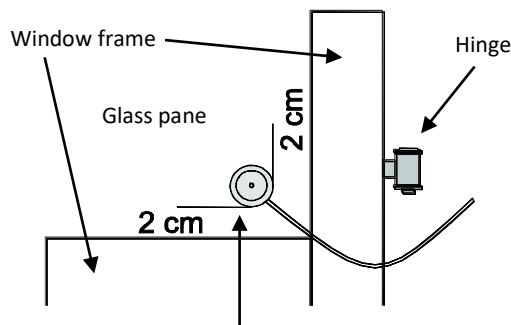

Minimum distances between detector and window

3. Clean the glass surface with the cleaning solvent (bottle no. 1). Let the surface dry.
4. Apply the enclosed sticker template for precise installation.
5. Clean the detector's bottom surface with the brown graining pad to remove any grease.
6. Apply activator (bottle no. 2) on the bottom surface of

the detector and on the installation spot. The sticker template (if used) will prevent staining the glass outside the installation area. Let the surfaces dry for 1-2 minutes.

7. Place a small drop of glue (bottle no. 3) in the centre of the detector's bottom surface and spread it evenly in a thin layer with enclosed triangular spatula. A thin layer is very important for a good and fast bond.
8. Press and hold the detector against the glass surface on the selected spot until you feel it adheres. (10 sec).
9. Let the glue harden for another 5 minutes before you start working with the cables.
10. Remove the surplus glue from the side of the detector using the triangular spatula. Remove the sticker template (if used).

See also <https://www.youtube.com/watch?v=fZd4SIEXbHI&t=13s>



## TECHNICAL DATA

Type of protected glass	Float and laminated glass (For other glass types and thicknesses, pls. contact Alarmtech)
Glass thickness	Float 4 mm to 6 mm, laminated P1A-P8B
Detection radius	2 m (P8B 1 m)
Supply voltage	8 – 15 VDC (DAY mode), 6 VDC (NIGHT mode)
Max. voltage ripple	0.2 Vpp @ 12 V
Current consumption quiescent	4 mA (@12 V)
Current consumption in alarm state	4.5 mA (@12 V)
Alarm output	Relay
Alarm indication	LED, DAY/NIGHT controlled
Day and night control	DAY=8 V, NIGHT=6 V supply voltage
Alarm time	Latches in case of alarm
Alarm reset	Disconnect supply voltage (<1 V)
Low voltage alarm or fault in electronics	<5V indicated by flashing LED
Cable	Spiral cable in PUR, 6 cores, length 35 cm – 70 cm (approx.)
Environmental class EN50130-5:2011, VdS 2110	IIIA
Operating temperature range	-40°C till +55°C
Operating humidity	max. 95% RH
Housing material	ABS Plastic in white, black or brown colour
Dimensions	Φ 27 mm, H 11 mm
Approvals	EN 50131-2-7-2 Grade 2 (EN-ST-000290), VdS 2332 Klasse B (G122508), SSF 1014-5 klass 2 (22-95), F&P (10.212-14918), FG (GD-1018/22)