



Box is sold separately

**DESCRIPTION**

The fuse module 3056 is designed for power distribution. It contains one power input with doubled input terminals, connecting to the power supply and four independently secured outputs. Outputs (+) in every channel are secured with separate fuses. Normal state of every channel is optically signaled by green LEDs. Failure detected in every channel (lack of voltage or activated fuse) is signaled by red LED and switch-over relay.

**FEATURES**

- DC or AC supply voltage
  - DC: 10 – 30 Vdc
  - AC: 8 – 20 Vac (rms)
- Four output channels independently secured with fuses
- Optical indication of output voltage in every channel (green LED)
- Optical indication of failure (red LED)
- Failure signalization with switch-over relay
- Relay contacts ratings 2 A / 30 V

**TECHNICAL SPECIFICATION**

Supply voltage DC	10 ÷ 30 V
Supply voltage AC	8 ÷ 20 Vrms, 47 ÷ 63 Hz
Maximum input current	8 A
Number of output channels	4
Maximum output current in every channel	< 2 A
Output fuses S1 to S4	T2AH250V
Failure relay	SPDT relay
Failure relay contact ratings	30 Vdc, 2 A
Supply current (relay energized, normal state)	22 mA @ 12 Vdc, 32 mA @ 24 Vdc
Environmental class	EN 50130-5, Class II
Dimensions	116 x 40 x 16 mm
Weight	55 g
Operating temperature	-20 °C to +55 °C
Compliance	

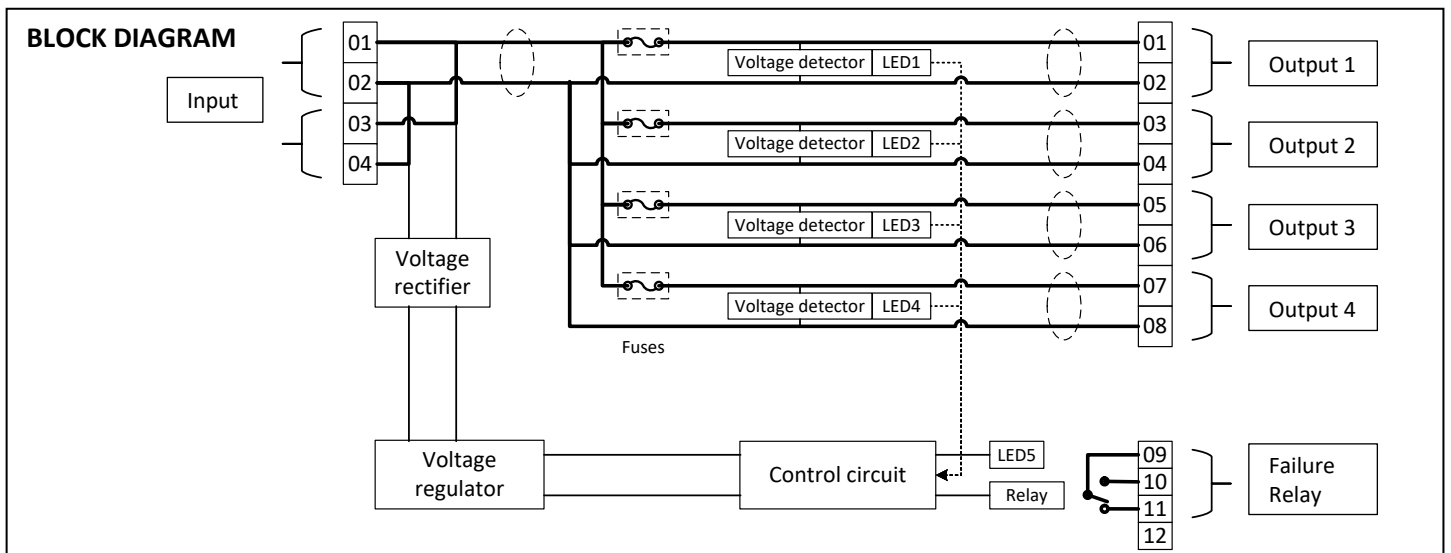

## I/O TERMINALS

### Input terminal

#	Function	
01	Supply voltage DC or AC	(+) or AC1
02	Common	(-) or AC2
03	Supply voltage DC or AC	(+) or AC1
04	Common	(-) or AC2

### Relay terminal

#	Function
09	Common
10	Normally Open
11	Normally Closed
12	Spare

### Output terminals

#	Function	Fuse	LED
01	Output channel 1	(+) output or AC1	S1 LED1
02	Common	(-) output or AC2	
03	Output channel 2	(+) output or AC1	S2 LED2
04	Common	(-) output or AC2	
05	Output channel 3	(+) output or AC1	S3 LED3
06	Common	(-) output or AC2	
07	Output channel 4	(+) output or AC1	S4 LED4
08	Common	(-) output or AC2	

## MOUNTING AND CONNECTION DIAGRAM

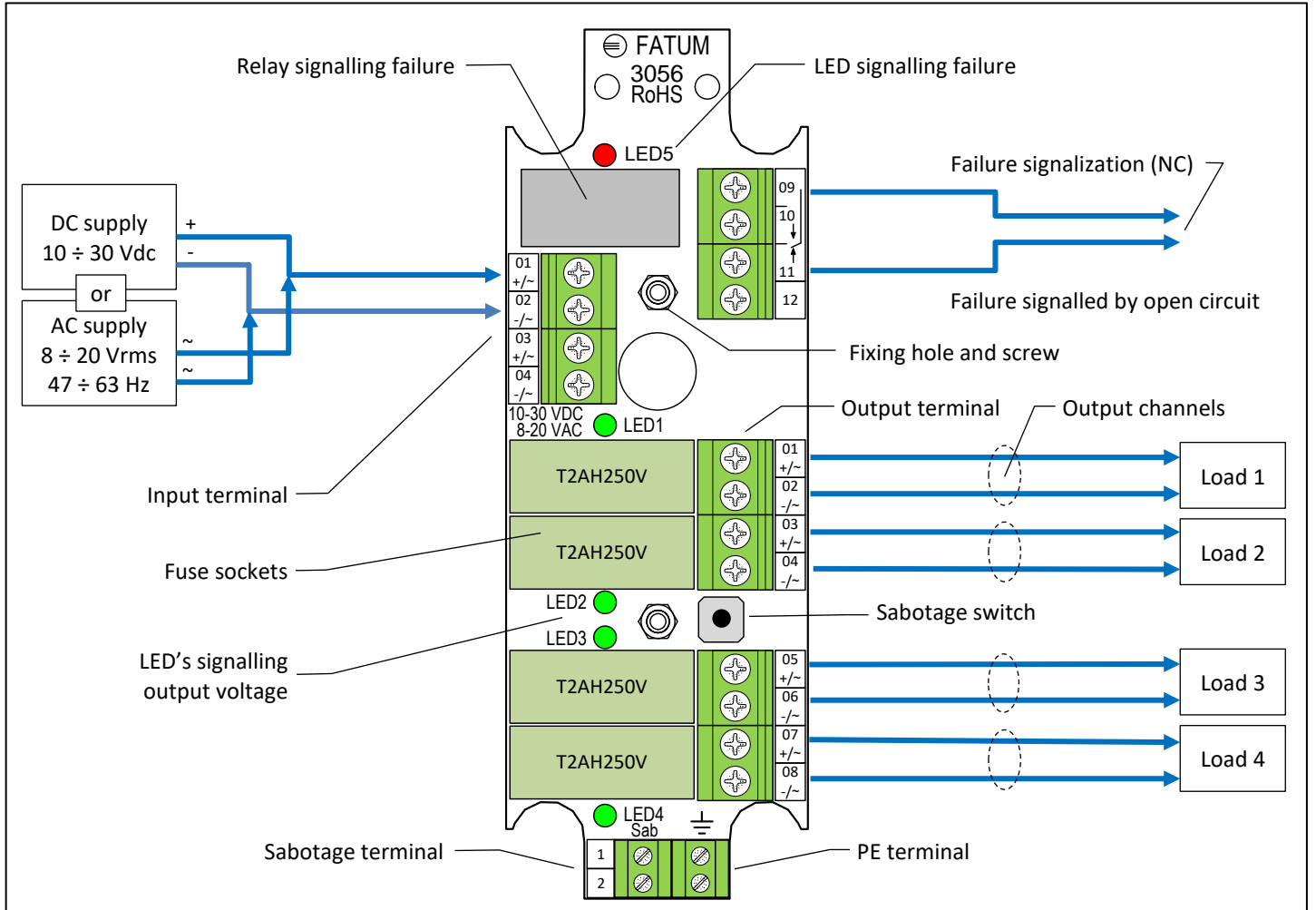

## FAILURE SIGNALIZATION (examples)

State of fuse module	Output voltage signalization				Failure LED	Failure relay	
	LED1	LED2	LED3	LED4	LED6	C-NC circuit	C-NO circuit
Normal, unit supplied	ON	ON	ON	ON	OFF	Closed	Open
Fuse in channel 1 activated	OFF	ON	ON	ON	ON	Open	Closed
Fuse in channel 2 activated	ON	OFF	ON	ON	ON	Open	Closed
Fuse in channel 3 activated	ON	ON	OFF	ON	ON	Open	Closed
Fuse in channel 4 activated	ON	ON	ON	OFF	ON	Open	Closed
Fuses in channel 1 and 2 activated	OFF	OFF	ON	ON	ON	Open	Closed
Fuses in channel 1 and 3 activated	OFF	ON	OFF	ON	ON	Open	Closed
Fuses in channel 2, 3 and 4 activated	ON	OFF	OFF	OFF	ON	Open	Closed
All fuses activated	OFF	OFF	OFF	OFF	ON	Open	Closed
Lack of supply voltage	OFF	OFF	OFF	OFF	OFF	Open	Closed